

LAGUNA®

JX | 6 Jointer



Owner's Manual
506601 AU
JX6
29/3/2021



For immediate service on any Laguna Tools products:

**Contact your local
distributor :
CARBATEC PTY LTD
Toll Free: 1800 658 111
www.carbatec.com.au**

Laguna Tools, Inc. LAGUNA® and the LAGUNA Logo® are the registered trademarks of Laguna Tools, Inc. All rights reserved. 04/01/2019



LAGUNA AMERICAN HEADQUARTERS

Texas: 744 Refuge Way Suite 200, Grand Prairie, Texas 75050, U.S.A. Phone:

+1-800-332-4094

Huntington Beach: 7291 Heil Ave Huntington Beach, CA 92647, U.S.A. Phone:

+1-949-474-1200

South Carolina: 825 Bistline Dr. Ste 101, West Columbia, SC 29172, U.S.A. Phone:

+1-800-234-1976

Minnesota: 5250 West 74th St, Edina, MN 55439, U.S.A Phone: +1-949-474-1200

lagunatools.com

supermaxtools.com

lagunacleanair.com

lagunalathe.com

LAGUNA EUROPE

Walker Rd, Bardon Hill, Coalville LE67 1TU, United Kingdom. Phone: +44-1530-516921

lagunatools.uk

DAKE CORPORATION

724 Robbins Road, Grand Haven, MI 49417, United States +1-800-937-3253

dakecorp.com

CONTENTS

JX|6 Jointer

Safety	4
Electrical Safety	8
Specifications	10
Machine Overview	11
Setup	12
Placement & Unboxing	13
Inventory List	14
Assembling	15
Operation	17
Maintenance	20
Troubleshooting	23
Wiring	24
JX6 Parts	26
Warranty	32

Safety

Read and understand all warnings and operation instructions before using any tool or equipment. Always follow basic safety precautions to reduce the risk of personal injury. Improper operation, maintenance or modification of tools or equipment could result in serious injury and property damage. There are certain applications for which tools and equipment are designed. This product should NOT be modified and/or used for any application other than for which it was designed.

It is important for you to read and understand this manual. The information it contains relates to protecting your safety and preventing problems.

Safety Call-outs

⚠ DANGER!

A POTENTIALLY HAZARDOUS SITUATION WHICH, IF NOT AVOIDED, COULD RESULT IN DEATH OR SERIOUS INJURY.
SOMETIMES DISPLAYED AS **⚠ DANGER!**

⚠ WARNING

A POTENTIALLY HAZARDOUS SITUATION WHICH, IF NOT AVOIDED, COULD RESULT IN DEATH OR SERIOUS INJURY.
SOMETIMES DISPLAYED AS **⚠ WARNING!**











⚠ CAUTION!

A POTENTIALLY HAZARDOUS SITUATION WHICH, IF NOT AVOIDED, MAY RESULT IN MINOR OR MODERATE INJURY.
SOMETIMES DISPLAYED AS **⚠ CAUTION!**

NOTICE!

A HELPFUL TIP FROM OUR TECHNICAL STAFF. SOMETIMES DISPLAYED AS NOTICE!

Safety Symbols

- | | | | |
|---|--|---|--------------------------|
|  | Disconnect from power before proceeding. |  | Wear ear protection. |
|  | Be aware of possible laceration danger. |  | Wear Eye Protection. |
|  | Be aware of possible crushing danger. |  | Wear a full face shield. |
|  | Be aware of possible crushing danger. |  | Wear lung protection. |
|  | Electrical Hazard. |  | Requires X People |

⚠ PROP 65 WARNING

SOME DUST CREATED BY POWER SANDING, SAWING, GRINDING, DRILLING, AND OTHER CONSTRUCTION ACTIVITIES CONTAINS CHEMICALS KNOWN TO THE STATE OF CALIFORNIA TO CAUSE CANCER, BIRTH DEFECTS OR OTHER REPRODUCTIVE HARM. SOME EXAMPLES OF THESE CHEMICALS ARE:

- LEAD FROM LEAD-BASED PAINTS.
- CRYSTALLINE SILICA FROM BRICKS, CEMENT AND OTHER MASONRY PRODUCTS.
- ARSENIC AND CHROMIUM FROM CHEMICALLY-TREATED LUMBER.

YOUR RISK FROM THESE EXPOSURES VARIES, DEPENDING ON HOW OFTEN YOU DO THIS TYPE OF WORK. TO REDUCE YOUR EXPOSURE TO THESE CHEMICALS: WORK IN A WELL VENTILATED AREA, AND WORK WITH APPROVED SAFETY EQUIPMENT, SUCH AS THOSE DUST MASKS THAT ARE SPECIALLY DESIGNED TO FILTER OUT MICROSCOPIC PARTICLES.

⚠ APPLICATIONS WARNING

- THIS MACHINE WAS DESIGNED FOR CERTAIN APPLICATIONS ONLY. WE STRONGLY RECOMMEND THAT THIS MACHINE NOT BE MODIFIED AND/OR USED FOR ANY APPLICATION OTHER THAN THAT FOR WHICH IT WAS DESIGNED. IF YOU HAVE ANY QUESTIONS RELATIVE TO A PARTICULAR APPLICATION, DO NOT USE THE MACHINE UNTIL YOU HAVE FIRST CONTACTED THE MANUFACTURER TO DETERMINE IF IT CAN OR SHOULD BE PERFORMED ON THE PRODUCT.
- IF YOU HAVE ANY QUESTIONS RELATIVE TO ITS APPLICATION DO NOT USE THE PRODUCT UNTIL YOU HAVE CONTACTED THE MANUFACTURER AND WE HAVE ADVISED YOU.

⚠ WARNING!

Machine & Workshop Safety Instructions

Read and understand all warnings and operating instructions before using this equipment. Failure to follow all instructions listed below, may result in electric shock, fire, and/or serious personal injury or property damage. Machinery can be dangerous if safe and proper operating procedures are not followed. As with all machinery, there are certain hazards involved with the operation of the product. Using the machine with respect and caution will considerably lessen the possibility of personal injury. However, if normal safety precautions are overlooked or ignored, personal injury to the operator may result. Safety equipment such as guards, push sticks, hold-downs, feather boards, goggles, dust masks and hearing protection can reduce your potential for injury. But even the best guard won't make up for poor judgment, carelessness or inattention. Always use common sense and exercise caution in the workshop. If a procedure feels dangerous, don't try it. Figure out an alternative procedure that feels safer. REMEMBER: Your personal safety is your responsibility.

OWNER'S MANUAL. Read and understand this owner's manual BEFORE using machine.

TRAINED OPERATORS ONLY. Untrained operators have a higher risk of being hurt or killed. Only allow trained/supervised people to use this machine. When machine is not being used, disconnect power, remove switch keys, or lock-out machine to prevent unauthorized use—especially around children. Make your workshop kid proof!

DANGEROUS ENVIRONMENTS. Do not use machinery in areas that are wet, cluttered, or have poor lighting. Operating machinery in these areas greatly increases the risk of accidents and injury.

MENTAL ALERTNESS REQUIRED. Full mental alertness is required for safe operation of machinery. Never operate under the influence of drugs or alcohol, when tired, or when distracted.

ELECTRICAL EQUIPMENT INJURY RISKS. You can be shocked, burned, or killed by touching live electrical components or improperly grounded machinery. To reduce this risk, only allow qualified service personnel to do electrical installation or repair work, and always disconnect power before accessing or exposing electrical equipment.

DISCONNECT POWER FIRST. Always disconnect machine from power supply BEFORE making adjustments, changing tooling, or servicing machine. This prevents an injury risk from unintended start-up or contact with live electrical components.

EYE PROTECTION. Always wear ANSI-approved safety glasses or a face shield when operating or observing machinery to reduce the risk of eye injury or blindness from flying particles. Everyday eyeglasses are NOT approved safety glasses.

WEARING PROPER APPAREL. Do not wear clothing, apparel or jewelry that can become entangled in moving parts. Always tie back or cover long hair. Wear non-slip footwear to reduce risk of slipping and losing control or accidentally contacting cutting tool or moving parts.

HAZARDOUS DUST. Dust created by machinery operations may cause cancer, birth defects, or long-term respiratory damage. Be aware of dust hazards associated with each workpiece material. Always wear a NIOSH-approved respirator to reduce your risk.

HEARING PROTECTION. Always wear hearing protection when operating or observing loud machinery. Extended exposure to this noise without hearing protection can cause permanent hearing loss.

REMOVE ADJUSTING TOOLS. Tools left on machinery can become dangerous projectiles upon startup. Never leave chuck keys, wrenches, or any other tools on machine. Always verify removal before starting!

USE CORRECT TOOL FOR THE JOB. Only use this tool for its intended purpose—do not force it or an attachment to do a job for which it was not designed. Never make unapproved modifications, modifying tool or using it differently than intended may result in malfunction or mechanical failure that can lead to personal injury or death!

AWKWARD POSITIONS. Keep proper footing and balance at all times when operating machine. Do not overreach! Avoid awkward hand positions that make workpiece control difficult or increase the risk of accidental injury.

CHILDREN & BYSTANDERS. Keep children and bystanders at a safe distance from the work area. Stop using machine if they become a distraction.

GUARDS & COVERS. Guards and covers reduce accidental contact with moving parts or flying debris. Make sure they are properly installed, undamaged, and working correctly BEFORE operating machine.

FORCING MACHINERY. Do not force machine. It will do the job safer and better at the rate for which it was designed.

NEVER STAND ON MACHINE. Serious injury may occur if machine is tipped or if the cutting tool is unintentionally contacted.

STABLE MACHINE. Unexpected movement during operation greatly increases risk of injury or loss of control. Before starting, verify machine is stable and mobile base (if used) is locked.

USE RECOMMENDED ACCESSORIES. Consult this owner's manual or the manufacturer for recommended accessories. Using improper accessories will increase the risk of serious injury.

UNATTENDED OPERATION. To reduce the risk of accidental injury, turn machine OFF and ensure all moving parts completely stop before walking away. Never leave machine running while unattended.

MAINTAIN WITH CARE. Follow all maintenance instructions and lubrication schedules to keep machine in good working condition. A machine that is improperly maintained could malfunction, leading to serious personal injury or death.

DAMAGED PARTS. Regularly inspect machine for damaged, loose, or wrongly adjusted parts—or any condition that could affect safe operation. Immediately repair/replace BEFORE operating machine. For your own safety, DO NOT operate machine with damaged parts!

MAINTAIN POWER CORDS. When disconnecting cord-connected machines from power, grab and pull the plug—NOT the cord. Pulling the cord may damage the wires inside. Do not handle cord/plug with wet hands. Avoid cord damage by keeping it away from heated surfaces, high traffic areas, harsh chemicals, and wet/damp locations.

WARNING!

Jointer Specific Safety Instructions

LIKE ALL MACHINES, THERE IS DANGER ASSOCIATED WITH THE MACHINE. INJURY IS FREQUENTLY CAUSED BY LACK OF KNOWLEDGE OR FAMILIARITY. USE THIS MACHINE WITH RESPECT. IF NORMAL SAFETY PRECAUTIONS ARE OVERLOOKED OR IGNORED, SERIOUS PERSONAL INJURY MAY OCCUR.

1. KICKBACK

"KICKBACK" IS WHEN THE WORK PIECE IS THROWN OFF THE JOINTER TABLE BY THE CUTTER HEAD. ALWAYS USE PUSH BLOCKS AND SAFETY GLASSES TO REDUCE THE LIKELIHOOD OF INJURY FROM "KICKBACK". THE "KICKBACK ZONE", IS THE PATH DIRECTLY THROUGH THE END OF THE IN FEED TABLE. NEVER STAND OR ALLOW OTHERS TO STAND IN THIS AREA DURING OPERATION. IF KICK BACK OCCURS, SEVERE INJURY MAY RESULT.

2. CUTTER HEAD ALIGNMENT

TO REDUCE THE POSSIBILITY OF KICKBACK, KEEP THE TOP EDGE OF THE OUT FEED TABLE ALIGNED WITH THE CUTTER HEAD INSERT AT TOP DEAD CENTER (TDC).

3. PUSH BLOCKS

THE CUTTER HEADS ARE EXTREMELY DANGEROUS AND YOU MUST NEVER PASS YOUR HANDS OVER THE CUTTER HEAD. ALWAYS USE PUSH BLOCKS WHENEVER SURFACE PLANNING. HAND SAFETY. IT IS GOOD PRACTICE TO MOVE THE HANDS IN AN ALTERNATE MOTION FROM BACK TO FRONT AS THE WORK CONTINUES THROUGH THE CUT. NEVER PASS YOUR HANDS DIRECTLY OVER THE CUTTERHEAD. AS ONE HAND APPROACHES THE CUTTERHEAD REMOVE IT FROM THE STOCK IN AN ARC MOTION AND PLACE IT BACK ON THE STOCK IN A POSITION BEYOND THE CUTTERHEAD. YOUR HANDS MUST NEVER BE CLOSER THAN 3 INCHES TO THE CUTTER HEAD.

4. SUPPORTING THE WORK

ONLY MAKE CUTS IF THE WORK PIECE IS STABLE AND NEVER ATTEMPT TO CUT UNSTABLE PLANKS, OR INJURY MAY OCCUR.

5. CUTTING DEPTH

NEVER EXCEED THE MAXIMUM CUTTING DEPTH AS STATED IN THE SPECIFICATION FOR YOUR MACHINE. IT IS FAR BETTER TO TAKE SEVERAL SMALL CUTS RATHER THAN LARGE CUTS.

6. DIRECTION OF CUT

JOINTING AGAINST THE GRAIN OR JOINTING END GRAIN IS DANGEROUS AND COULD PRODUCE CHATTER OR EXCESSIVE CHIP OUT. ALWAYS JOINT WITH THE GRAIN.

7. GUARDS

GUARDS ARE DESIGNED TO REDUCE THE RISK OF INJURY. ALWAYS USE THE GUARDS. IF IT IS IMPERATIVE TO USE THE MACHINE WITHOUT THE GUARDS, [RABBETING] ALWAYS REPLACE THE GUARDS.

8. CUTTING DIRECTION

ONLY CUT FROM THE IN FEED TABLE TO THE OUT FEED TABLE, AND ALWAYS COMPLETE THE CUT. DO NOT STOP THE WOOD PROGRESS UNTIL THE JOB HAS CLEARED THE CUTTER HEAD COMPLETELY. ONLY CUT WITH THE GRAIN OR AT A SLIGHT ANGLE TO THE GRAIN.

9. STOCK

YOUR SAFETY WILL BE GREATLY ENHANCED IF YOU ONLY USE GOOD LUMBER. ONLY WORK WITH LUMBER AFTER YOU HAVE INSPECTED IT COMPLETELY. STAPLES, NAILS LOOSE KNOTS AND ANY OTHER METAL IN THE PLANK WILL DAMAGE YOUR CUTTER HEAD AND COULD CAUSE INJURY AND OR FIRE. IF YOU HAVE ANY QUESTION ABOUT A PIECE OF LUMBER, DO NOT USE IT.

**SAVE THESE INSTRUCTIONS.
Refer to them often and use them to instruct others.**

Electrical Safety

⚠ WARNING!

- RUNNING ON A DIFFERENT VOLTAGE THAN STATED BELOW WILL DAMAGE THE MACHINE. NEVER RUN THE MACHINE IN WET OR DAMP CONDITIONS.
- ELECTROCUTION, FIRE, SHOCK, OR EQUIPMENT DAMAGE MAY OCCUR IF MACHINE IS NOT PROPERLY GROUNDED AND CONNECTED TO POWER SUPPLY.

Motor Specifications

The typical main motor is a 1.5 HP and is wired for 230 Volt, Single-Phase, 50 HZ, AC current. Confirm your motor electrical configuration before connecting power! Before connecting the machine to the power source, make sure the starter and switches are in the "OFF" position.

Power Supply

A separate electrical circuit should be used for each machine. This circuit should not be less than the wiring listed below and should be protected with an appropriate circuit breaker based on the total running and start-up amperage's (listed below). If an extension cord is used, use only 3-wire extension cords which have 3-prong grounding type plugs and matching receptacle which will accept the machine's plug.

506601

VOLTAGE	230V
PHASE	1PH
HERTZ	50Hz

Grounding Methods

⚠ DANGER!

THIS MACHINE MUST BE GROUNDED WHILE IN USE TO PROTECT THE OPERATOR FROM ELECTRIC SHOCK. IN ALL CASES, MAKE CERTAIN THAT THE RECEPTACLE IN QUESTION IS PROPERLY GROUNDED. IF YOU ARE NOT SURE, HAVE A QUALIFIED ELECTRICIAN CHECK THE RECEPTACLE.



1. All grounded, cord-connected machines:

In the event of a malfunction or breakdown, grounding provides a path of least resistance for electric current to reduce the risk of electric shock. This tool is equipped with an electric cord having an equipment-grounding conductor and a grounding plug. The plug must be plugged into a matching outlet that is properly installed and grounded in accordance with all local codes and ordinances.

Do not modify the plug provided - if it will not fit the outlet, have the proper outlet installed by a qualified electrician.

Improper connection of the equipment-grounding conductor can result in a risk of electric shock. The conductor with insulation having an outer surface that is green with or without yellow stripes is the equipment-grounding conductor. If repair or replacement of the electric cord or plug is necessary, do not connect the equipment-grounding conductor to a live terminal.

Check with a qualified electrician or service personnel if the grounding instructions are not completely understood, or if in doubt as to whether the tool is properly grounded.

Use only 3-wire extension cords that have 3-prong grounding plugs and 3 pole receptacles that accept the tool's plug.

Repair or replace damaged or worn cord immediately.

Specifications

JX|6 Jointer

JX6 506601 AU

MOTOR:	230V 1.5HP 1PHASE 50HZ
BED SIZE	6 X 60" (152 x 1524mm)
INFEED TABLE PULL-OUT EXTENSION	8" (200mm)
RABBETTING CAPACITY	1/2" (12.7mm)
FENCE SIZE	29"X3-3/4" (736 x 95mm) CAST IRON
FENCE TILT	±45/90 DEGREE
MAX. DEPTH OF CUT	1/8" (3.2mm)
TABLE HEIGHT FROM FLOOR	31" (787mm)
SAFETY BAR SHUT-OFF	YES
WHEELS BUILT-IN	YES
BRACKET TO MOUNT LIGHT	NO
UTLET FOR LIGHT	NO
BRACKET TO MOUNT FEEDER	NO
DUST PORT DIAMETER	4" (100mm)
CUTTERHEAD INSERT #	Helical with 21x 4-sided Carbide inserts
CUTTERHEAD RPM	5500
CUTTERHEAD DIAMETER	2-1/2" (63mm)
BED ADJUSTMENT	PARALLELOGRAM
DIMENSIONS SET UP APPROX.	63" X 22" (1600mm x 558mm)
DIMENSIONS SHIPPING	65"X 22"X 13" (1650 x 558 x 330mm) + 31"X 16"X 27" (787 x 406 x 685mm)
NET/SHIP WEIGHT # OF BOXES	161/174lbs (73/79kg) + 88/94lbs (40/43kg) 2x BOXES

Machine Overview

JX|6 Jointer

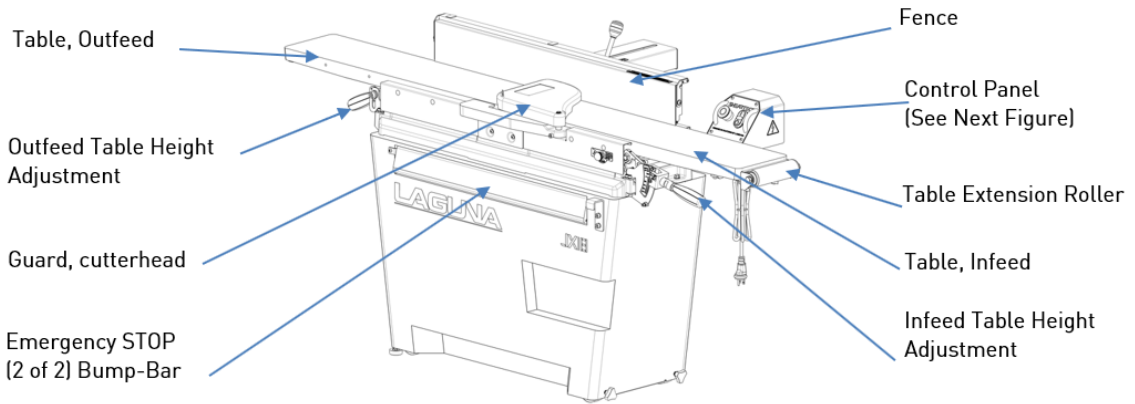
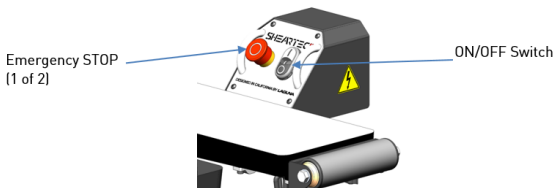

Figure 6: Main Components



- A. Emergency Stop (E-STOP); stops all functions of machine, however, power continues to machine. **NOTICE!** To reset E-STOP, rotate switch clockwise until the button “pops” out. **NOTICE!** E-STOP bump bar (red) located on front of frame.
- B. ON/OFF Switch; Starts and Stops rotation of cutterhead. **NOTICE!** Will not work of the E-STOP is engaged.

Setup

Setup Overview (MUST READ)

When setting up your Jointer, please take a moment to read this overview prior to starting.

The machine comes mostly assembled. You will have to assemble the leveling feet and calibrate the thickness scale.

After Setup, There may be a few adjustment to be made. All of these adjustments are done prior to shipping the machine, however if additional adjustments are required please follow the adjustment guides.

⚠ CAUTION! If you have any doubt about the described procedure, seek professional assistance. Do not attempt any procedure that you feel is unsafe, or that you do not have the physical capability of achieving.

Placement

Before you remove your machine from the packaging, select the area where you will use your machine. There are no hard and fast rules for its location, but below are a few guidelines:

1. There should be sufficient area at the front of the machine to allow you to work on it comfortably.
2. There should be sufficient area at the back of the machine to allow access for adjustments and maintenance to be conducted.
3. Adequate lighting. The better the lighting the more accurately and safely you will be able to work.
4. Solid floor. You should select a solid flat floor, preferably one made of concrete or something similar.
5. Locate it close to a power source and dust collection.
6. Allow an area for the storage of blanks, finished products and tools.

Unboxing

⚠ WARNING!

- THE MACHINE WEIGHS 174 LBS (78KG). ENSURE THAT YOU HAVE ENOUGH PEOPLE TO DO THE JOB SAFELY.
- IF YOU HAVE ANY DOUBT ABOUT THE DESCRIBED PROCEDURE, SEEK PROFESSIONAL ASSISTANCE. DO NOT ATTEMPT ANY PROCEDURE THAT YOU FEEL IS UNSAFE, OR THAT YOU DO NOT HAVE THE PHYSICAL CAPABILITY OF ACHIEVING.

This step requires a forklift, or several helpers. The machine is heavy, be careful when lifting and handling it! Failure to comply may cause serious injury and/or damage to the machine and/or property!



FIGURE 3: BOX 1 - JOINTER TOP/BED



FIGURE 4: BOX 2 - JOINTER BASE AND MOTOR

The Jointer comes packed in two boxes. Before attempting to assemble this machine, follow these directions:

1. Cut all the straps away from the packaging.
2. Open the taller box first. This is the base of the machine.
3. Carefully remove the base from the box and remove the styrofoam protection.
4. Open the long box which contains the jointer bed.
5. Remove any packing material such as cardboard or foam.
6. Using the information below, ensure that all parts are present and in good condition.

Inventory List

The following depicts items shipped with your machine. Before assembling, ensure that you have received all parts shown below. Machine parts should arrive sealed in plastic bags. Remove parts from plastic bags before laying them out to inventory them.

Inventory

- 2 Push Blocks
- 1 3mm Hex Wrench
- 1 6mm Hex Wrench
- 1 8/10mm Wrench
- 1 11/13mm Wrench

Tools/items Required: Assembly & Adjustment

- T-25 Torx Wrench
- 3mm Hex Wrench
- 6mm Hex Wrench
- 8mm Hex Wrench (not included)
- 8/10mm Wrench
- 11/13mm Wrench

DANGER!

FOR YOUR OWN SAFETY, DO NOT CONNECT THE MACHINE TO THE POWER SOURCE UNTIL THE MACHINE IS COMPLETELY ASSEMBLED! PLEASE ALSO MAKE SURE THAT YOU READ AND UNDERSTAND THE ENTIRE MANUAL.

Assembling

Machine Preparation and Setup:

1. The machine is supplied with four installed wheels, two of which are locking style (infeed side). Lock these two wheels, by turning the thumbscrew clockwise, when the machine is placed and before operation (Fig. 4). Loosen the two thumbscrews when moving the jointer.
2. With help, lift the top bed of the machine onto the base. Carefully move the unit so the bolt holes are aligned, between the bed and cabinet and insert bolts, but do not fully tighten.
3. Remove the back cover from the cabinet, to provide access to the pulley and belt on the motor.
4. Within the movement the bolts allow, align the pulley on the cutterhead with the pulley on the motor, in a vertical plane as closely as possible.
5. Install the belt on both pulleys. The motor may need to be loosened on its adjustable plate to achieve this. Once installed, ensure adequate tension on the belt by adjusting the motor, then lock in place.
6. Tighten the mounting bolts between the cabinet and machine top. Install the rear pulley cover plate with the included screws. Install the spring-return cutterhead guard.
7. Clean all rust protected surfaces with a commercial de-greaser. DO NOT use acetone, gasoline, lacquer thinner or any type of cleaner that could damage paint. Coat cleaned surfaces with WD-40® or Teflon based lube.

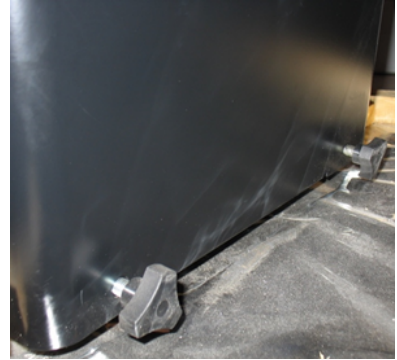

FIGURE 5: WHEEL LOCKS

⚠ CAUTION!

BE CAREFUL WHEN WORKING ON OR NEAR CUTTERHEAD AS THE KNIVES ARE VERY SHARP!

Power Supply Circuit Requirements

The power source circuit for your machine must be grounded and rated for the amperage given below. Never replace a circuit breaker on an existing circuit with one of higher amperage without consulting a qualified electrician to ensure compliance with wiring codes. If you are unsure about the wiring codes in your area or you plan to connect your machine to a shared circuit, consult a qualified electrician.

Circuit Size 1.5 HP (230v, Single Phase)10 Amp (minimum)

⚠ DANGER!

IN ALL CASES, MAKE CERTAIN THE RECEPTACLE IN QUESTION IS PROPERLY GROUNDED. IF YOU ARE NOT SURE, HAVE A QUALIFIED ELECTRICIAN CHECK THE RECEPTACLE.

Motor Specifications

The standard main motor is 1.5 HP and is typically wired for 230 Volt, Single Phase, 50 HZ, AC current. Confirm your motor electrical configuration before connecting power! Before connecting the machine to the power source, make sure the starter and/or switches are in the "OFF" position.

⚠ WARNING

WHEN COMPLETED, THE MACHINE MUST CONFORM TO THE NATIONAL ELECTRIC CODE AND ALL LOCAL CODES AND ORDINANCES.

Connecting Power (See also wiring diagram)

1. Plug power cord into 10 Amp (min.), 230 Volt, Single Phase, dedicated circuit

DISCONNECT POWER SUPPLY TO JOINTER BEFORE CONTINUING! ONLY CONNECT POWER WHEN REQUIRED.

Calibrating the Thickness Scale

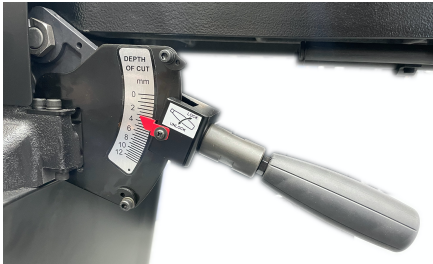

FIGURE 13: THICKNESS SCALE



FIGURE 14: LOCK PIN

1. Loosen the Infeed Table locking handle by rotating counterclockwise (Fig. 13).
2. Pull and hold the Lock Pin (Fig. 14) while positioning handle to 0.5mm. Tighten handle.
3. Make a test cut half-way on sample material. Measure The depth of cut/stock removal on the sample. If not 0.5mm, adjust pointer to actual cut dimension by loosening the Phillips screw and adjusting red pointer and tightening the Philips screw.

Adjusting the Fence

The fence can be adjusted to use all or a portion of the cutterhead. To adjust, loosen the Locking Handle (Fig. 15) and slide to position fence in desired location.

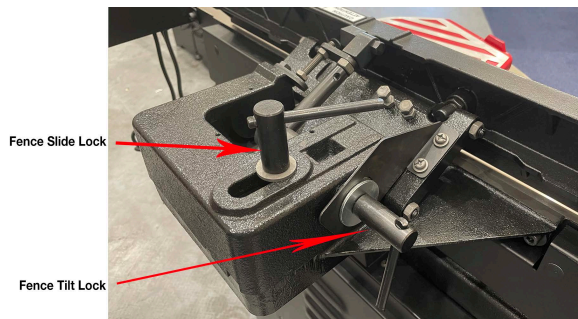

FIGURE 15: FENCE SLIDE COMPONENTS

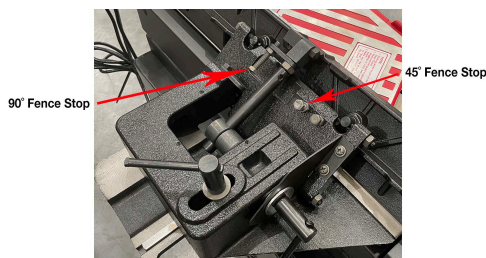

FIGURE 16: FENCE ANGLE ADJUSTMENT COMPONENTS

NOTICE! The 90-degree position has an included reference STOP (Fig. 16). To adjust, flip the stop into position, loosen the lock nut and rotate the adjusting screw until the fence is at 90 degrees to the table. Tighten the lock nut and flip the stop back if making other angled adjustments. To check the 90 degree setting, place a square on the outfeed table and against the fence.

To adjust the fence perpendicular or angled to the bed, loosen the Locking Lever (Fig. 15) and adjust the fence to the desired position.

Operation

⚠ CAUTION!

PLACE THE JOINTER ON A SECURE AND STABLE SURFACE FOR OPERATION. CLAMP OR BOLT THE JOINTER INTO POSITION.

1. Establish the proper depth of cut. 0.5mm is the recommended maximum cut for the best finish with least chance of kick-back when jointing.



FIGURE 22: INFEEED TABLE EXTENSION

NOTICE! The infeed table extension (Fig. 22) can be extended for support of long material. Loosen the two locking studs under the bed, pull extension out and tighten the two locking studs.

2. Start dust collection.
3. Start jointer.
4. Feed stock into cutterhead, while maintaining contact of the stock on the bed and against the fence. Maintain control and support of stock as the stock opens the guard and contacts the cutterhead. Maintain a good, firm stance while pushing stock across the jointer. Move hands along stock when feeding to maintain control of stock. Lift hands from stock as they come near cutterhead and reposition them on outfeed side. **DO NOT allow hands to come within three inches of the cutterhead.**
5. Reposition yourself to the outfeed side of jointer and control and support stock until it is past cutterhead and the guard has fully closed.

⚠ WARNING

USE PUSH BLOCKS FOR FACE JOINTING! DO NOT PLACE YOUR HANDS NEAR CUTTERHEAD OR GUARD!

Edge and Face jointing:

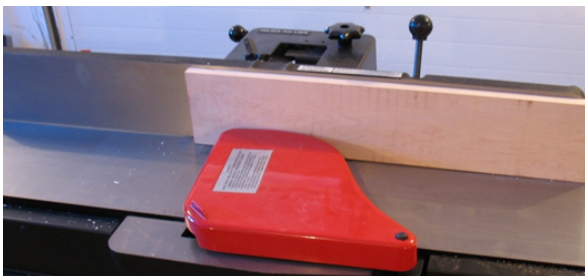

FIGURE 17: EDGE JOINTING



FIGURE 18: FACE JOINTING

Beveling

The fence can be adjusted up to 45 degrees angled toward the infeed/outfeed tables (bed) or away from the infeed/outfeed tables (bed) for beveling. There is less chance of stock slippage when the fence is angled down, toward the tables (Fig. 19). Angling the fence toward the tables is also a safer method to bevel, when the application allows.

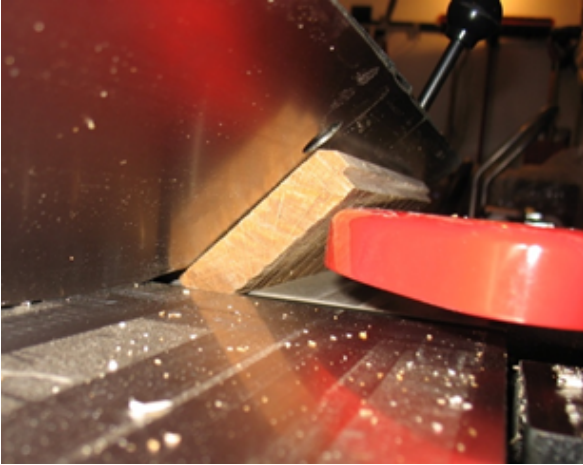

FIGURE 19: BEVELING

NOTICE!

THE TWO 45-DEGREE POSITIONS INCLUDE TWO REFERENCE STOPS (FIG. 16). TO ADJUST, LOOSEN THE LOCK NUT AND ROTATE THE ADJUSTING SCREW UNTIL THE FENCE IS AT 45 DEGREES TO THE TABLE, ANGLED IN OR OUT.

Rabbeting

Rabbeting is a groove along the edge of stock. The stock can be on edge or face, depending on the dimensions required for the rabbet.

Position fence for width of rabbet cut. This is the distance from the outmost edge of the outermost knife insert to the fence.

Set depth of cut with the Infeed Table Adjustment Handle. Do not set deeper than 0.5mm per pass. Several passes may be required to reach the desired depth. Adjust the infeed table for each pass (0.5mm max.) until the rabbet is completed.



FIGURE 20: RABBETING

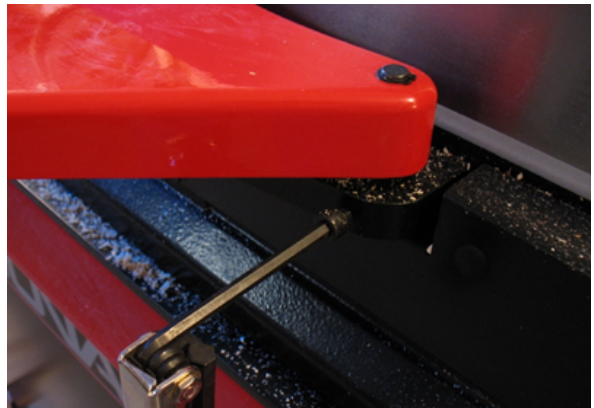

FIGURE 21: REMOVING GUARD FOR RABBETING

NOTICE!

(SPRING LOADED GUARD (RED) MAY NEED TO BE REMOVED FOR RABBETING WIDE STOCK.) LOOSEN HEX BOLT AND LIFT GUARD WITH PIN FROM MACHINE (FIG. 21).

⚠ DANGER!

REPLACE GUARD AS SOON AS MACHINE STOPS AFTER RABBET IS CUT!
NEVER ALLOW HANDS NEAR CUTTERHEAD WHEN THE GUARD IS REMOVED!

Maintenance

General

Keep your machine clean. At the end of each day, clean the machine. Wood contains moisture, and if sawdust or wood chips are not removed they will cause rust.

In general, we recommend that you only use a Teflon-based lubricant on the machine. Regular oil attracts dust and dirt. Teflon lubricant tends to dry and has less of a tendency to accumulate dirt and saw dust.

Periodically check that all nuts and bolts are tight.

Daily checks

1. Clean the machine and lubricate unpainted surfaces with a Teflon lubricant. Wipe off any excess and buff with a dry polishing cloth. This will reduce the likelihood of rust forming and reduce the friction on the tables as the wood is machined.
2. Check knife inserts for nicks and sharpness.
3. Generally inspect the machine for damage and loose or worn parts.

Weekly checks

1. Clean the cutter head. Do not touch knife inserts!
2. Check knife inserts for nicks and sharpness.
3. Generally inspect the machine for damage and loose or worn parts.
4. Check the dust extraction for blockages and any large pieces that could cause blockages.

Monthly checks

1. Check the drive belt for wear, splits and cuts.
2. Clean the motor compartment and the motor to ensure that the motor cooling fins work efficiently.
3. Generally inspect the machine for damage and loose or worn parts. NOTICE! It is recommended that you use a Teflon based lubricant.

Routine Inspections

It is a good idea to routinely inspect any quality woodworking tool in order to keep it in optimum condition. This includes inspecting all hardware for tightness, ensuring the filter is clean, and cleaning debris and grime from any surfaces and moving parts. In addition, make sure to:

- Clean out-feed rollers and table with a non-flammable solvent to remove pitch, gum and other unwanted build-up.
- Periodically clean the inside of the machine for dust control.
- Keep pulleys and belts free from dirt, dust, oil and grease.
- Replace worn belts as needed.
- Replace worn knives or sharpen.

Knife rotation/replacement

⚠ CAUTION!

KNIFE INSERTS ARE DANGEROUSLY SHARP. USE EXTREME CAUTION WHEN INSPECTING, REMOVING, OR REPLACING KNIFE INSERTS.

⚠ WARNING

- TURN JOINTER OFF AND DISCONNECT POWER BEFORE PERFORMING ANY MAINTENANCE OR ADJUSTMENTS!
- MAKE SURE ALL KNIFE INSERT SCREWS ARE TIGHTENED SECURELY. LOOSE INSERTS CAN BE PROPELLED AT HIGH SPEED FROM A ROTATING CUTTERHEAD, CAUSING INJURY.
TORQUE EACH SCREW TO 52-60 IN/LBS.

Shear-Tec II Cutterhead



Figure 23: Shear-Tec II Cutterhead

1. The knife inserts are four-sided. When dull, remove each knife, rotate it 90° for a fresh edge, and re-install it. No further adjustment is necessary. Use a Torx wrench to remove the knife insert screw.
DO NOT USE YOUR HAND TO HOLD THE CUTTERHEAD! See Fig. 23b. ⚠ WARNING!
2. It is advisable to rotate all inserts at the same time to maintain consistent cutting. However, if one or more knife inserts develops a nick, rotate only those inserts that are affected. Each knife insert has an etched reference mark so you can keep track of the rotation. **Torque each screw to 52-60 in/lbs.**
3. **IMPORTANT:** When removing or rotating inserts, clean sawdust from the screw, the insert, and the cutterhead platform. Dust accumulation between these elements can prevent the insert from seating properly and may affect the quality of the cut.
4. Before installing each screw, lightly coat the screw threads with machine oil and wipe off any excess. Securely tighten each screw which holds the knife inserts before operating the jointer!

Outfeed Table Adjustment:

⚠ WARNING

- TURN OFF AND DISCONNECT POWER BEFORE PERFORMING ANY MAINTENANCE OR ADJUSTMENTS!

The outfeed table is adjusted at the factory to be level with (or within .006" of) the Top Dead Center (TDC) of the knife inserts.

To adjust the Outfeed Table, loosen the Adjustment Lock (Fig. 24) for the Outfeed Table with an 8mm hex wrench (not included). Adjust the height of the Outfeed Table with the Adjustment Handle for the Outfeed Table (Fig. 24). Tighten the Adjustment Lock.

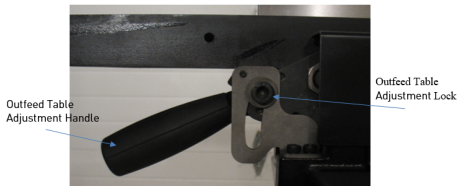

FIGURE 24: OUTFEED TABLE ADJUSTMENT

Poly Drive Belt Adjustment:

⚠ WARNING

- TURN OFF AND DISCONNECT POWER BEFORE PERFORMING ANY MAINTENANCE OR ADJUSTMENTS!

The poly-drive-belt tension is set at the factory. Proper tension is achieved when the belt can be depressed approximately 1/4" mid-way between the pulleys.

If adjustment is needed remove the four screws holding the back panel to the stand of the jointer.

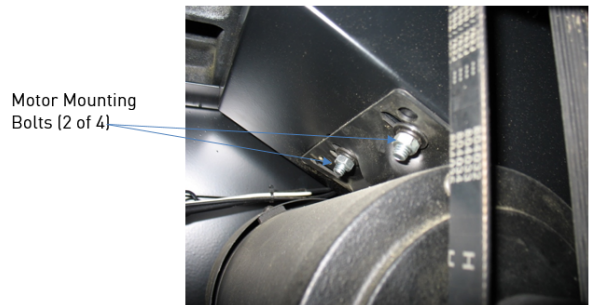

FIGURE 25: TWO OF THE FOUR MOTOR MOUNTING BOLTS

The motor is attached with four bolts on a slide. Loosen the four motor mount bolts to tension the drive belt by sliding the motor downward (Fig. 25).

When the drive belt is properly tensioned, tighten the four motor mounting bolts and replace the back cover.

Troubleshooting

Symptom	Possible Cause	Possible Solution
MACHINE WILL NOT START	<ol style="list-style-type: none"> 1. FUSE BLOWN OR CIRCUIT BREAKER TRIPPED 2. CORD DAMAGED 3. NOT CONNECTED TO POWER SOURCE 4. CONNECTED TO WRONG VOLTAGE 5. EMERGENCY STOP BUTTON PRESSED 	<ol style="list-style-type: none"> 1. REPLACE FUSE OR RESET CIRCUIT BREAKER 2. HAVE CORD REPLACED 3. CHECK CONNECTION 4. CHECK VOLTAGE 5. ROTATE EMERGENCY STOP BUTTON CLOCKWISE UNTIL IT POPS OUT
CUTTERHEAD DOES NOT COME UP TO SPEED	<ol style="list-style-type: none"> 1. LOW CURRENT 2. MOTOR NOT WIRED FOR CORRECT VOLTAGE 	<ol style="list-style-type: none"> 1. CONTACT LOCAL ELECTRIC COMPANY 2. REFER TO MOTOR NAMEPLATE FOR CORRECT VOLTAGE
WORKPIECE DIFFICULT TO PUSH	<ol style="list-style-type: none"> 1. TOO MUCH MATERIAL BEING REMOVED IN ONE PASS 2. DULL KNIVES 	<ol style="list-style-type: none"> 1. REDUCE THE AMOUNT OF MATERIAL BEING REMOVED 2. ROTATE OR REPLACE KNIVES
SHRIMP	<ol style="list-style-type: none"> 1. MATERIAL NOT SUPPORTED PROPERLY AS IT EXITS OUTFEED TABLE 2. OPERATOR PUSHING DOWN ON TRAILING END OF MATERIAL 3. OUTFEED TABLE TOO LOW 	<ol style="list-style-type: none"> 1. SUPPORT MATERIAL FOR ENTIRE CUT 2. ELIMINATE DOWNWARD PRESSURE ON TRAILING END 3. ADJUST OUTFEED TABLE LEVEL WITH CUTTERHEAD ACHIEVED
FUZZY GRAIN	<ol style="list-style-type: none"> 1. WOOD WITH A HIGH MOISTURE CONTENT 2. DULL KNIFE INSERT(S) 	<ol style="list-style-type: none"> 1. ALLOW WOOD TO DRY PROPERLY 2. ROTATE OR REPLACE 3. KNIFE INSERT(S)
LINE(S) OR RIDGES IN FINISHED SURFACE	<ol style="list-style-type: none"> 1. NICKED OR DAMAGED KNIFE INSERT(S) 	<ol style="list-style-type: none"> 1. ROTATE OR REPLACE 2. KNIFE INSERT(S)

Dust Collection

To ensure proper operation and longest knife life it is important to maintain full air flow to your dust collection system. Make sure the filter media is clean and there are no obstructions in the ducting or hoses.

Wiring

⚠ WARNING

REVIEW [ELECTRICAL SAFETY](#) PRIOR TO ANY WIRING PROCEDURES.

506601 (JX6)

VOLTAGE	230V
PHASE	1PH
HERTZ	50Hz
FULL LOAD AMPERAGE	10Amp
<p>⚠ WARNING! Below are RECOMMENDATIONS to be used for this machine based on the above information. Variables that may affect this are:</p> <ul style="list-style-type: none"> • Actual voltage supplied to the machine • Electrical code that must be met in your local province. <p>An electrician will verify that all the demands are met to properly wire the machine. If you have absolutely any doubt when wiring this machine - please consult with a qualified electrician.</p>	
PLUG/RECEPTACLE	Not Included
WIRING (Gauge)	See Jacket Printing

JX6 Shear-Tec:II Parts

Wiring Diagram

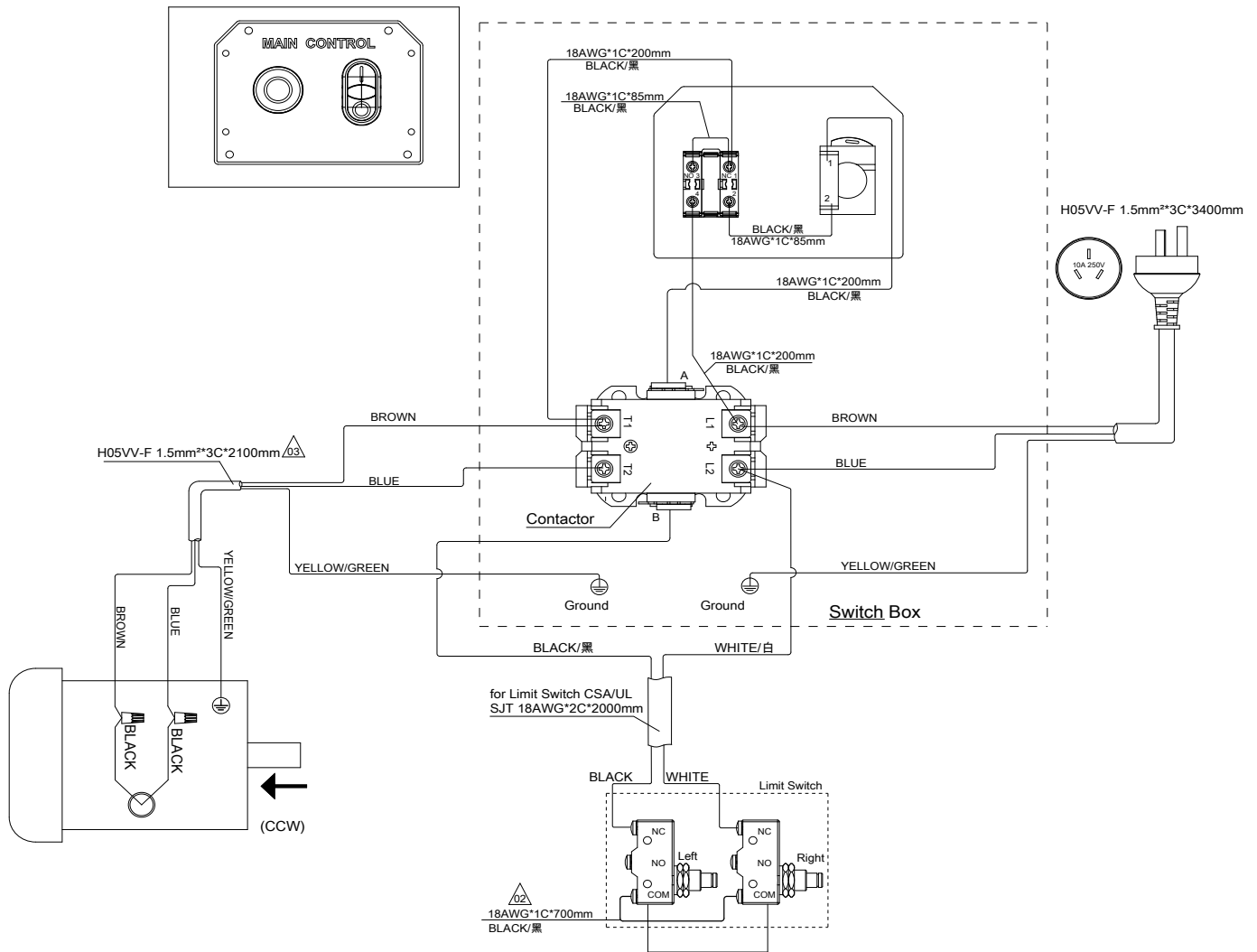

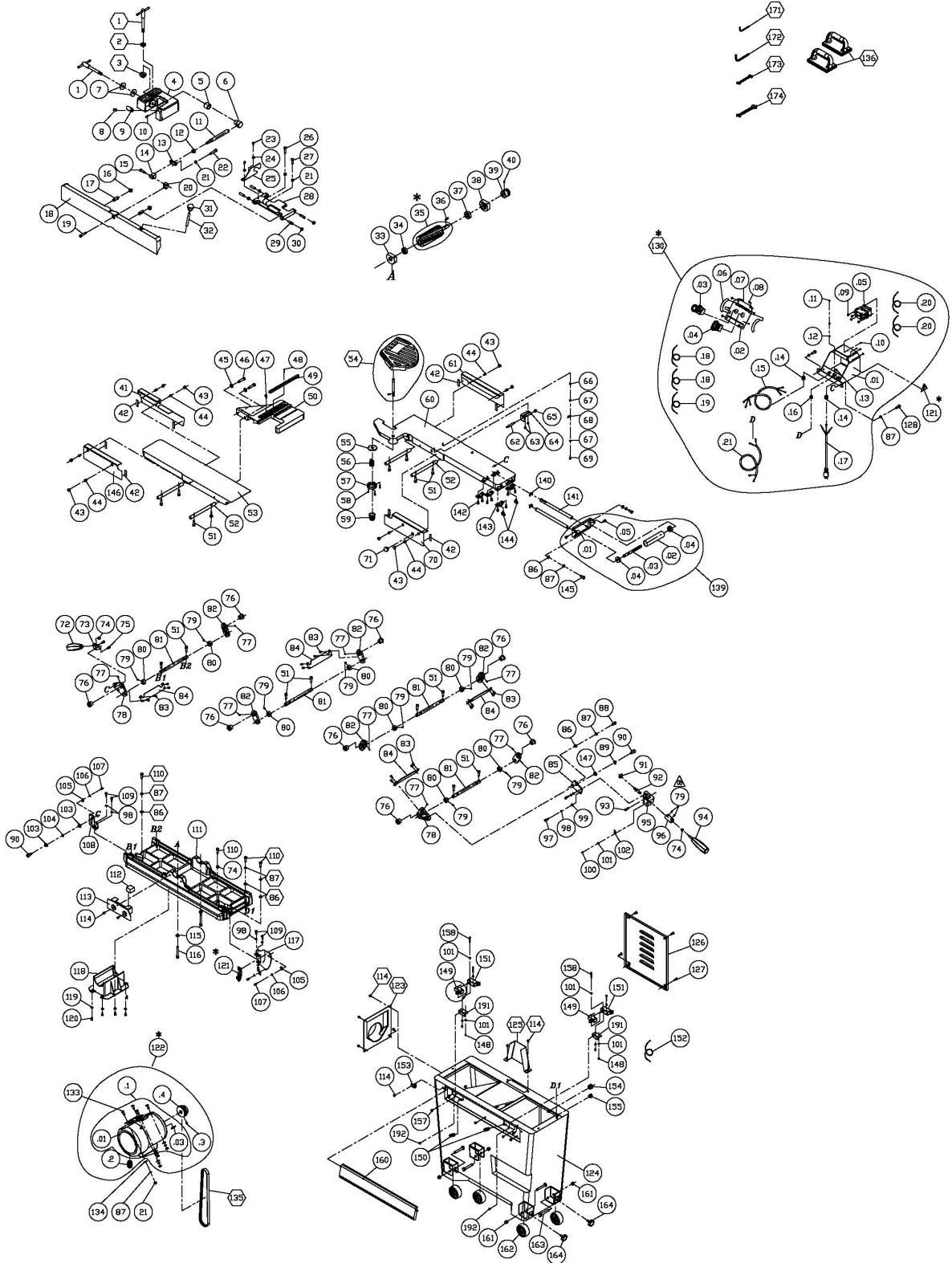

JX6 Shear-Tec II Parts

506601 Part List

Key	Part No.	Descriptions	Specification	Q'ty
1	360034-901	Knob Fence		2
2	006003-091	Flat Washer	13*28*3.0t	1
3	380209-901	T-Nut		1
4	051301-196	Fence Bracket - Upper		1
5	130055-903	Sleeve		1
6	130009-903	Fixing Block		1
7	006003-097	Flat Washer	13.5*40*3.0t	2
8	290003-901	Bolt		1
9	170047-901	Stop Plate		1
10	011002-103	Spring Pin	4*12	2
11	360068-901	Fixing Rod		1
12	009008-300	Hex. Nut	7/16"-14NC(17.4B*9.52H)	1
13	170598-901	Fence Stop		1
14	130007-903	Pivot		1
15	290004-901	Bolt		1
16	009010-100	Hex. Nut	1/2"-20NF(19.05B*6.35H)	2
17	360676-901	Stud Pivot		2
18	051300-196	Fence		1
19	003602-702	Flat Hd Soc. Screw	5/16"-18NC*1-5/8"	1
20	130008-903	Pivot		1
21	009005-300	Hex. Nut	5/16"-18NC(12.7B*6.75H)	7
22	003003-708	Hex. Screw	5/16"-18NC*1-3/4"	1
23	003301-701	Pan Head Screw	1/4"-20NC*1/2"	2
24	006003-023	Flat Washer	6.3*13*2t	6
25	170048-901	Safty Plate		1
26	003003-706	Hex. Screw	5/16"-18NC*1-1/4"	1
27	003003-705	Hex. Screw	5/16"-18NC*1"	1
28	051303-000	Tilt Plate		1
29	230015-901	Stud		4
30	009022-300	Hex. Nut	3/8"-16NC(13.83B*6.68H)	4
31	250372-615	Fence Tilt Knob		1
32	360038-901	Handle Rod		1
33	050018-901	Bearing Housing		1
34	030206-002	Ball Bearing	6202	1
35	924974-001	Sprial Cutterhead Assembly	3 Slots	1
	924976-001	Sprial Cutterhead		1
	038201-702	Torx Screw	#10-32UNF*12.5	21
	210114-000	Knife	15*15*2.5t	21
	040703-000	Torx Wrench	T-25	2
36	012003-009	Key	5*5*25	1
37	030207-002	Ball Bearing	6203	1
38	050019-901	Bearing Housing		1
39	381427-902	Pulley		1
40	001902-101	SET Lock Screw	M6*1.0P*10	1
41	174794-196	Rear Base Cover - L		1
42	200024-615	Packing		8
43	042505-000	Cord Plug	HP-13	8
44	000103-102	CAP Screw	M6*1.0P*10	8
45	006001-163	Flat Washer	8.5*19*3t	2

506601 Part List

Key	Part No.	Descriptions	Specification	Q'ty
46	000104-110	CAP Screw	M8*1.25P*30	2
47	003103-102	CAP Screw	1/4"-20NC*1/2"	1
48	011002-105	Spring Pin	4*20	1
49	380080-000	Key		1
50	051445-000	Fence Bracket		1
51	000104-108	CAP Screw	M8*1.25P*25	16
52	361373-902	Support Shaft		4
53	051443-000	Outfeed Table		1
54	920155-001	Cutterhead Guard Assembly		1
55	170045-901	Retainer Ring		1
56	280009-000	Spring		1
57	110004-000	Retaining Knob		1
58	003305-206	Pan Head Screw	5/32"-32NC*5/8"	3
59	110024-000	Knob		1
60	051459-008	Table Infeed	LAGUNA	1
61	174793-196	Rear Base Cover - R		1
62	361327-902	Handle Shaft Bolt		1
63	290028-901	Shoulder Screw		2
64	174603-902	Fixing Plate		1
65	009103-100	Lock Nut	1/4"-20NC(11B*8H)	1
66	008004-100	Hex. Nut	M5*0.8P(8B*4H)	1
67	006001-009	Flat Washer	5.2*10*1.0t	2
68	280082-000	Tension Spring		1
69	000102-116	CAP Screw	M5*0.8P*15	1
70	174796-196	Front Cover - R		1
71	230156-615	Knob Plunger	22*1/4"-20NC	1
72	230141-615	Handle		1
73	174786-904	Plate		1
74	008006-100	Hex. Nut	M8*1.25P(13B*6.5H)	3
75	000102-104	CAP Screw	M5*0.8P*12	2
76	130350-903	Bushing		8
77	001901-102	Set Locking Screw	M5*0.8P*8	8
78	130351-903	Connecting Rod Plate		2
79	001902-102	SET Lock Screw	M6*1.0P*8	10
80	361241-902	Bushing		8
81	361374-902	Rod		4
82	130352-903	Rod Plate		6
83	002603-101	CAP Lock Screw	M5*0.8P*10	16
84	174790-000	Fixing Rod Plate		4
85	174784-904	Fixing Plate		1
86	006001-049	Flat Washer	8.5*16*2.0t	6
87	006305-100	Lock Washer	8.2*13.7	16
88	000104-104	CAP Screw	M8*1.25P*16	1
89	006307-100	Lock Washer	10.2*18.5	1
90	000105-101	CAP Screw	M10*1.5P*20	2
91	130393-903	Inclined Block		1
92	361370-902	Handle Shaft Bolt		1
93	002602-101	CAP Lock Screw	M6*1.0P*12	1
94	230191-000	Miter Gauge Handle		1

506601 Part List

Key	Part No.	Descriptions	Specification	Q'ty
95	310548-911	Fixed Bolck		1
96	381428-902	Bushing		1
97	000103-108	CAP Screw	M6*1.0P*25	2
98	006303-100	Spring Washer	6.5*10.5	7
99	006001-022	Flat Washer	6.3*13*1.0t	2
100	000302-101	Pan Head Phillips Screw	M4*0.7P*6	1
101	006001-001	Flat Washer	4.3*10*1.0t	9
102	174782-156	Pointer		1
103	006003-080	Flat Washer	10.5*23*3.0t	2
104	006703-100	Wave Wahser	WW-10	1
105	174785-904	Fixing Plate		3
106	006502-100	Teeth Washer	5.3*10(BW-5)	3
107	000102-103	CAP Screw	M5*0.8P*10	3
108	174787-904	Locking Plate - L		1
109	000103-105	CAP Screw	M6*1.0P*15	5
110	000003-105	Hex. Screw	M8*1.25P*25	4
111	051444-196	Base		1
112	200105-615	Sponge	30*30*22(L*W*H)	1
113	174797-196	Cutterhead Front Cover		1
114	000801-101	Round Head Hex. Screw	M6*1.0P*10	8
115	006306-100	Sprinb Washer	9.8*17.8	2
116	003111-302	CAP Screw	3/8"-24NF*2-1/2"	2
117	174783-904	Locking Plate - R		1
118	924851-001	Chip Hood Assembly	6"	1
119	006002-032	Flat Washer	6.6*13*1.0t	4
120	000304-203	Pan Head Phillips Screw	M6*1.0P*12	4
122	901296-001	Motor Assembly	1.5HP*230V*50HZ*1PH	1
123	250036-615	Dust Chute		1
124	174933-196	Stand		1
125	174795-196	Pulley Cover		1
126	170445-196	Cover		1
127	000403-104	Flat Head Phillips Screw	M6*1.0P*20	4
128	000104-106	CAP Screw	M8*1.25P*20	2
128	000104-106	CAP Screw	M8*1.25P*20	4
129	174695-902	Hook		2
130	950818-001	Control Box Assembly	208-240V	1
133	003801-202	Carriage Bolt	5/16"-18NC*3/4"	4
134	006001-053	Flat Washer	8.5*19*2.0t	4
135	014367-000	Poly-V-Belt	320J-6	1
136	250035-629	Push Block		2
139	924987-001	Extension Roller Assembly	6"	1
140	010208-000	Retaining Ring	ETW-12	2
141	361414-902	Extension Rod		2
142	000103-103	CAP Screw	M6*1.0P*12	8
143	130405-903	Bushing Block		4
144	250705-000	Wing Screw	M6*1.0P	2
145	000003-104	Hex. Screw	M8*1.25P*20	2
146	174792-196	Front Cover - L		1
147	006001-069	Flat Washer	10*20*3.0t	1

506601 Part List

Key	Part No.	Descriptions	Specification	Q'ty
148	008301-200	Lock Nut	M4*0.7P(7B*5H)	4
149	491101-000	LimiteSwitch	MJ2-1307	2
150	280274-000	Spring		2
151	490229-615	Cover for Limit Switch		2
152	471037-103	Connect Cord	18AWG*1C*550mm	1
154	020005-000	Strain Relief	SB8R-3	1
155	020008-000	Strain Relief	SBR5-2	1
156	000103-107	CAP Screw	M6*1.0P*20	2
157	340007-615	Block		5
158	000101-110	CAP Screw	M4*0.7P*30	4
159	008304-100	Lock Nut	M6*1.0P(10B*6H)	2
160	174934-156	Emergency Stop Plate		1
161	009102-100	Lock Nut	3/8"-16NC	4
162	250400-000	Wheel		4
163	003005-106	Hex. Screw	3/8"-16NC*2-1/2"	4
164	004001-101	Knob		2
171	040003-000	Hex. Wrench	3mm	1
172	040006-000	Hex. Wrench	6mm	1
173	040201-000	Open Wrench	8*10	1
174	040203-000	Open Wrench	11*13	1
191	174932-000	Limit Switch Bracket		2
192	001601-101	Round Head Phillips Screw w/Washer	M4*0.7P*8/4*10*0.8t	4

Warranty

This machine is covered by a warranty and the purchasing dealer can answer any questions you may have. Additionally, you can contact Laguna: +1 (949) 474-1200 customerservice@lagunatools.com.

Every product sold is warranted to be free of manufacturers' defective workmanship, parts, and materials. For any questions about this product, the intended use or what it was designed for, customer service, or replacement parts – please reach out to our customer service department.

REGISTRATION

TO PREVENT VOIDING THIS WARRANTY, ALL PRODUCTS SOLD MUST BE REGISTERED WITHIN THIRTY (30) DAYS OF RECEIVING. REGISTERING THE PRODUCT WILL ENABLE THE ORIGINAL PURCHASER TO RECEIVE NOTIFICATIONS ABOUT IMPORTANT PRODUCT CHANGES AND RECEIVE CUSTOMER SUPPORT.

[HTTPS://LAGUNATOOLS.COM/POLICIES/WARRANTY/](https://lagunatools.com/policies/warranty/)

WHAT IS COVERED?

ANY PART, DETERMINED BY LAGUNA TOOLS®, TO HAVE A DEFECT WILL BE REPAIRED OR REPLACED (AND SHIPPED), WITHOUT CHARGE. IT IS REQUIRED THAT THE DEFECTIVE ITEM/PART BE RETURNED TO LAGUNA TOOLS® WITH THE COMPLAINT AND PROOF OF PURCHASE IN THE ORIGINAL PACKAGING THAT IT WAS RECEIVED. IN THE EVENT THE ITEM/PART IS DETERMINED TO BE VOID OF THIS WARRANTY, THE CUSTOMER WILL BE RESPONSIBLE FOR THE COST TO REPLACE THE ITEM/PART AND ALL RELATED SHIPPING CHARGES.

WHO IS COVERED?

THE APPLICABLE WARRANTY COVERS ONLY THE INITIAL PURCHASER OF THE PRODUCT FROM THE RECEIPT DATE. THE ORIGINAL PURCHASER MUST PRESENT THE ORIGINAL RECEIPT AS PROOF OF PURCHASE.

SHIPPING DAMAGE

LAGUNA TOOLS® AND THE PURCHASING CUSTOMER IS NOT RESPONSIBLE FOR DAMAGE OR LOSS CAUSED BY A FREIGHT COMPANY OR OTHER CIRCUMSTANCES NOT IN THE DIRECT CONTROL OF LAGUNA TOOLS®. ALL SHIPPING RELATED CLAIMS FOR LOSS OR DAMAGED GOODS MUST BE MADE TO LAGUNA TOOLS WITHIN TWENTY-FOUR HOURS OF DELIVERY.

WARRANTY LIMITATIONS

THIS LIMITED WARRANTY DOES NOT APPLY TO NATURAL DISASTERS, ACTS OF TERRORISM, NORMAL WEAR AND TEAR, PRODUCT FAILURE DUE TO LACK OF MAINTENANCE OR CLEANING, DAMAGE CAUSED BY ACCIDENT, NEGLIGENCE, OR LACK-OF/INADEQUATE DUST COLLECTION. THE WARRANTY MAY BE VOIDED AGAINST PROOF OF MISUSE/ABUSE, DAMAGE CAUSED WHERE REPAIR OR ALTERATIONS HAVE BEEN MADE OR ATTEMPTED BY OTHERS, USING THE PRODUCT FOR PURPOSES OTHER THAN THOSE DESCRIBED AS INTENDED USE (UNLESS WITH CONSENT BY LAGUNA TOOLS®), MODIFICATION TO THE PRODUCT, OR USE WITH AN ACCESSORY THAT WAS NOT DESIGNED FOR THE PRODUCT. IT IS THE RESPONSIBILITY OF THE USER TO UNDERSTAND BASIC WOODWORKING MACHINERY SETTINGS AND PROCEDURES AND TO PROPERLY MAINTAIN THE EQUIPMENT IN ACCORDANCE WITH THE STANDARDS PROVIDED IN THIS MANUAL.

LENGTH OF WARRANTY

ASIDE FROM BEING FREE OF DEFECTS UPON RECEIVING, CONSUMABLE PARTS, LIKE CUTTERS AND ABRASIVES, ARE NOT COVERED BY THIS WARRANTY UNLESS OTHERWISE STATED BY LAGUNA TOOLS®. THESE PARTS ARE DESIGNED TO BE USED AT THE EXPENSE OF THE OPERATOR AND ARE AVAILABLE FOR REPLACEMENT OR INVENTORY PURCHASE.

2 YEAR – NEW PURCHASES THROUGH AUTHORIZED DEALERS.

1 YEAR – BLADES AND ACCESSORIES

Dealer Machinery Warranty

New woodworking machines sold by Laguna Tools carry a two-year warranty effective from the date of dealer invoice to consumer.

Laguna Tools guarantees all new machine sold to be free of manufacturers' defective workmanship, parts and materials. We will repair or replace, without charge, any parts determined by Laguna Tools, to be a manufacturer's defect. In the event the item/part is determined to be damaged due to lack of maintenance, cleaning or misuse/abuse, the customer will be responsible for the cost to replace the item/part, plus all related shipping charges. This limited warranty does not apply to natural disasters, acts of terrorism, normal wear and tear, product failure due to lack of maintenance or cleaning, damage caused by accident, neglect, lack of or inadequate dust collection, misuse/abuse or damage caused where repair or alterations have been made or attempted by others.

This manual applies to the JX6 jointer. Enter the model number and serial number below for quick reference when ordering accessories, supplies or parts. NOTE: The model and serial number plate can be found on back of the jointer.

Model: _____

Serial: _____

Contact your local distributor :
CARBATEC PTY LTD
Toll Free: 1800 658 111
www.carbatec.com.au

LAGUNA SuperMax



LAGUNA AMERICAN HEADQUARTERS

Texas: 744 Refuge Way Suite 200, Grand Prairie, Texas 75050, U.S.A. Phone: +1-800-332-4094
 Huntington Beach: 7291 Heil Ave Huntington Beach, CA 92647, U.S.A. Phone: +1-949-474-1200
 South Carolina: 825 Bistline Dr. Ste 101, West Columbia, SC 29172, U.S.A. Phone: +1-800-234-1976
 Minnesota: 5250 West 74th St, Edina, MN 55439, U.S.A Phone: +1-949-474-1200

DAKE CORPORATION

724 Robbins Road, Grand Haven, MI 49417, United States +1-800-937-3253

LAGUNA EUROPE

Walker Rd, Bardonia Hill, Coalville LE67 1TU, United Kingdom. Phone: +44-1530-516921