



Carbatec Half Blind 300 mm Dovetail Jig

CT-DTJ300 MANUAL

CARBATEC.COM.AU

carbatec®

1 YEAR
WARRANTY

THANK YOU FOR CHOOSING carbatec®

Carbatec has been a trusted brand for woodworking enthusiasts and professionals across Australia and New Zealand, since 1987.

Our quality woodworking products are designed and built to offer value and performance, making the latest features and technological advancements more accessible to Aussie woodworkers.

Backed by our no-fuss after-sales care and warranty support, you can trust Carbatec to keep you woodworking, as promised.

We look forward to sharing in your woodworking journey!

If you have any questions about our products or service, please call us on **1800 658 111** or email us at info@carbatec.com.au

Find us on social media



facebook.com/Carbatec



instagram.com/Carbatec



youtube.com/CarbaTecToolsForWood

WHAT'S IN THE BOX

The following items are provided in 1 carton:



CT-DTJ300 HALF BLIND 300 MM DOVETAIL JIG

- A. Pre-assembled jig
- B. Adjustment handles
- C. 1/4" shank 14° dovetail router bit

NOTICE

If you cannot find an item on this list, carefully check around and inside the machine and components. Often, these items get lost in packaging materials. Remove all packing from the carton and re-check.

SAFETY INSTRUCTIONS

This list of do's and do nots is not exhaustive and is not a substitute for common sense and best practises. Woodworking tools and machinery are potentially dangerous, it is important to observe all safety instructions whilst operating this equipment.

- Always wear eye and ear protection.
- Turn off and unplug all machinery from power source before making any adjustments.
- Always use a licensed electrician for any installation or electrical repair work.
- Do not wear loose clothing, jewellery or other loose ornamentation.
- Long hair should be protected by netting or other means to prevent ingress into the machine.
- Keep all safety guards in place and well maintained.
- Ensure all adjusting keys and spanners are removed before tool is operated.
- Keep children and unauthorised persons away from machines, even when not in use.
- Do not use tool for any other purpose other than that which it was designed.
- Do not use excessive force, or exceed capacity of tool.
- Wood dust is a serious health hazard, ensure appropriate dust extraction is fitted.
- Keep floor and adjacent areas clean and dry.
- Do not operate whilst under the influence of alcohol, drugs or medication.
- Use appropriate clamps and hold downs to secure work to bench top.

NOTE: WHEN OPERATING A ROUTER OBSERVE THE SAFETY INSTRUCTIONS SUPPLIED BY THE MANUFACTURER, OR RETAILER.

OVERVIEW

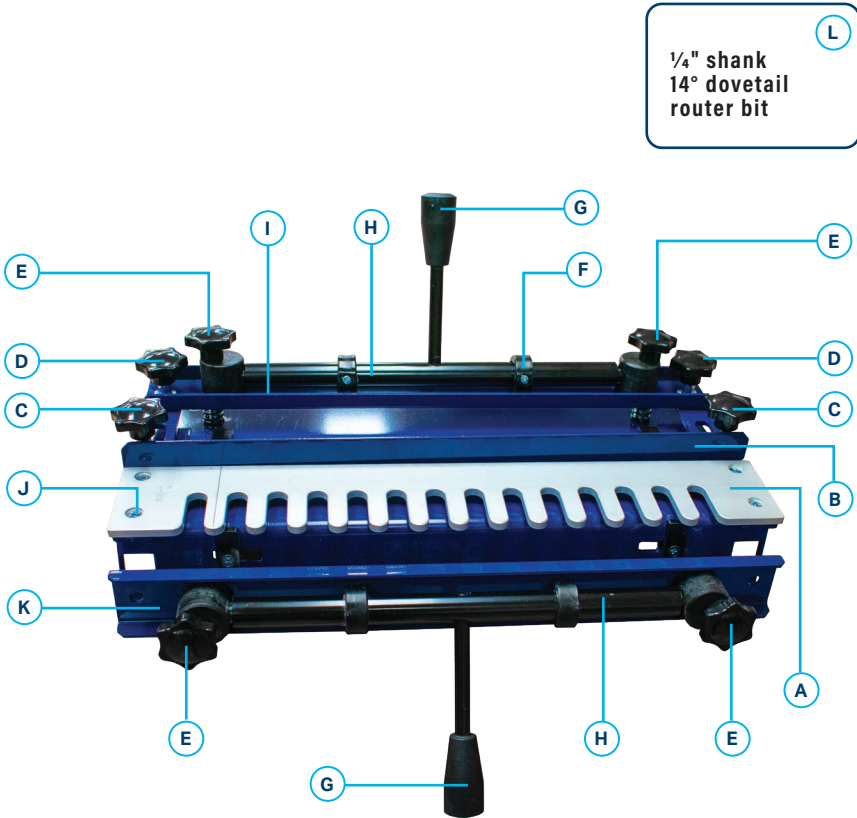

CT-DTJ300 HALF BLIND 300 MM DOVETAIL JIG

- | | |
|--|--|
| A. 1 x Comb | G. 2 x Eccentric bar handle |
| B. 1 x Backstop | H. 2 x Eccentric bar |
| C. 2 x Backstop fixing screw | I. 1 x Top clamp bar |
| D. 2 x Fixing screw - Top clamp bar | J. 4 x Comb securing screw |
| E. 4 x Adjusting screw | K. 1 x Front clamp bar |
| F. 4 x Eccentric cam | L. 1 x 1/4" shank 14° dovetail router bit |

SPECIFICATIONS

MAX. MATERIAL WIDTH 12" (300 mm)

MATERIAL THICKNESS Front and back pieces 1/2" (12 mm) to 1 1/4" (32 mm)
Side pieces 3/8" (9 mm) to 3/4" (18 mm)

JOINT SIZE The comb supplied will produce 1/2" (12.7 mm) pins and tails for the dovetail joint. To cut this joint, you will need to use the included router bit with bearing guide.

5/8" blind dovetails require an optional router bit with bearing.

1/2" box joints require an optional router bit with bearing.

For details on available and replacement router bits for this jig, search CT-DTJ300 on our website, www.carbatec.com.au

OVERALL SIZE (LxWxH) 270 x 440 x 160 mm

NETT WEIGHT 9 kg

A. SET UP INSTRUCTIONS. EXAMPLE OF A DRAWER DOVETAIL JOINT.

1. Fit the clamp handles to the jig. Mount the jig to a firm and stable work bench at a comfortable height, remembering that the router sits on top of the jig. The jig must be mounted close to the front edge so as to leave clear passage for the timber to the front vertical clamp. Also leave ample clearance to the rear of the jig to accommodate the longest length of timber you are likely to want to work a dovetail joint on.

The front clamp holds the side piece and the top clamp holds the front or back piece of the drawer. The complete joint will be cut in a single pass through the side piece (making the pins) and into the back or front piece (making the pocket).

2. Size and cut square your drawer components accurately. The dovetail joints are cut with the insides of the components facing out and the edge that will form the top of the drawer hard up against the side stops of the jig therefore the right-hand side of the drawer and corresponding front joint are cut on the left hand side of the jig and vice versa. It is a good idea to identify the drawer pieces so that the correct faces are presented.

3. Use a square to mark the centre of the first finger of the template comb. **(Fig. A1)**
4. Set the top left-hand stop (A) of the jig so that its inside face is in line with the mark you made on the first finger. **(Fig. A2)**

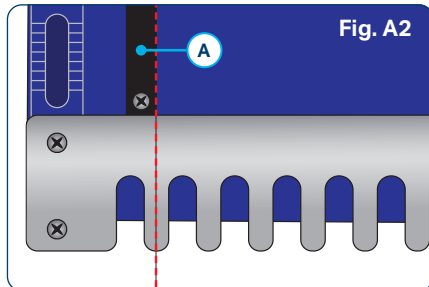

5. Offset the left-hand vertical stop (B) $\frac{1}{2}$ " to the right of the top-left horizontal stop (A). **(Fig. A3 & A4)**
6. Mirror these two adjustments on the right-hand side of the jig. Ensure that 90° alignment is maintained with the front edge of the jig at all times.
7. Place two pieces of timber (two perpendicular sides of the drawer) in the clamps. The edge of the top piece of timber lines up with the marked line. **(Fig. A5)**
8. Level the template comb with a piece of timber of the same thickness on the right-hand side of the jig. **(Fig. A6)**

8

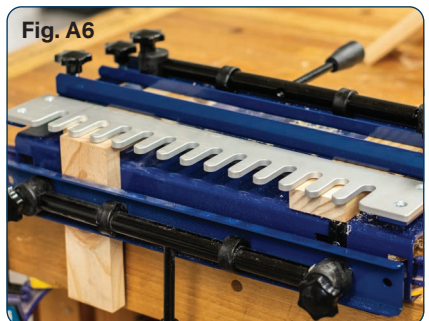
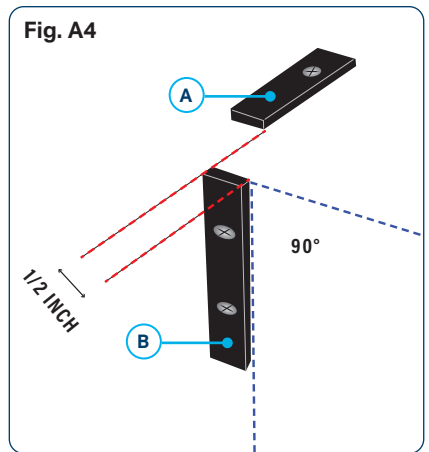
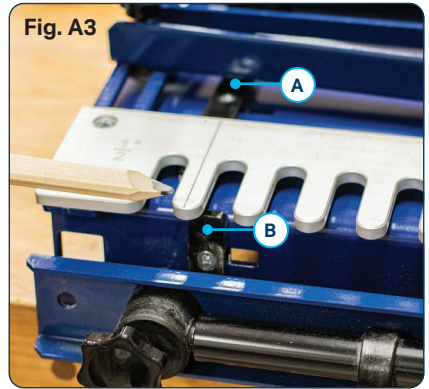

B. CUTTING INSTRUCTIONS

1. With the router positioned on the finger template but with the cutter clear of the work, start the router.
2. Now with just a light cut run the router **from right to left** across the work, just touching the end of each finger.
3. Continue the cut allowing the router to do the work and avoiding any heavy-handed forced contact with template.
4. Follow the template in and out of the finger guides working from left to right.
5. When completed switch the router off before lifting it from the jig.

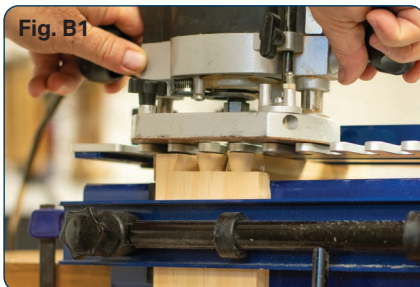

C. BOX JOINT

1. Set both pieces of wood to be jointed in the front vertical clamp, one positioned in line with but to the left of one of the fingers, the other in line with but to the right of one of the fingers, this will give you the offset for the joint. The depth of cut should be precisely the thickness of the timber being jointed so that the pins do not protrude from the sides.
2. If necessary raise the finger guides as detailed above to give better clearance for the cutter and improved bearing contact with the finger guide.
3. Ensure that the cutter will clear the jig bed before commencing the cut.
4. When completed switch the router off before lifting it from the jig.

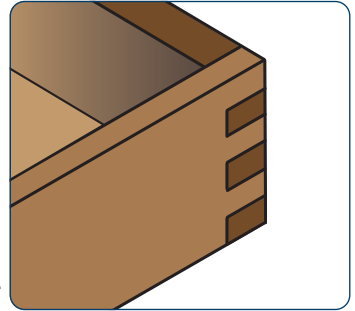

D. PRODUCTION

After refining the settings with the test cuts, production will proceed rapidly and accurately if you have paid attention to your setting up. However, do check periodically that things have remained accurate, making any corrections as necessary.

E. EQUALLY SIZED HALF PINS

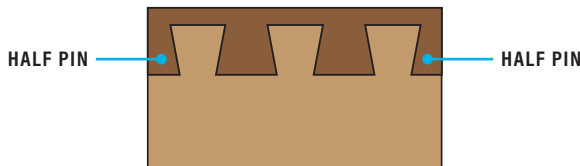

Fixed spacing jigs like this model have board widths that allow for equally sized half pins. By selecting a board width from the opposite chart, you will easily create equally sized half pins on either side of the joint. Additionally, you can increase the board width up to 6 mm (1/4") or reduce it by up to 3 mm (1/8"). This chart covers boards up to a maximum width of 305 mm (12"). Example: for a 248 mm (9 3/4") nominal width board, the actual board width can be from 245 mm (9 5/8") up to 254 mm (10") and still create even half pins on either end of the joint.

EVEN PINS BOARD WIDTH CHART Add up to 6 mm or subtract up to 3 mm
55 mm (2 3/4")
83 mm (3 1/4")
110 mm (4 3/8")
138 mm (5 7/16")
166 mm (6 1/2")
193 mm (7 5/8")
221 mm (8 11/16")
248 mm (9 3/4")
276 mm (10 7/8")
305 mm (12")

1 YEAR WARRANTY

- A. We warrant that this Carbatec product will be free from defects caused by faulty workmanship or faulty materials for a period of 1 year from date of sale.
- B. This warranty is in addition to other rights and remedies you may have under a law in relation to the goods.
- C. This warranty does not apply in any of the following cases:
- i. Defects arising from:
 1. fair wear and tear;
 2. corrosive atmosphere;
 3. damage or injury caused by deliberate act, lack of care or failure to comply with the recommended care and maintenance for the goods;
 4. improper use of the goods;
 5. alterations or repairs (not made by us) to the goods;
 - ii. defects arising from an event outside of our control such as fire, flood, earthquake or other natural calamity, motor vehicle or other accident, strike, civil unrest, terrorism or war;
 - iii. to accessory items such as after-market jigs, accessories or other items which are not sold or serviced by us and which are not sold with or were not included with the main unit purchased; or
 - iv. to wearable parts such as drive belts/ shafts, bearings, bandsaw tyres, motor brushes, blades or abrasive belts/discs or other cutting or machining implements.
 - v. damage caused to any electrical component, where connected to a power supply outside the country for which it was designed (namely Australia or New Zealand).
- D. If this warranty applies and you have complied with the procedure below for making a claim, we will, at our election, either repair the goods (or those parts of the goods recognised as defective) or will provide a replacement within a reasonable time at our expense.
- E. If this warranty applies, the procedure for making a claim is:
- i. you must contact us by email;
 - ii. you must include in the email the following information:
 1. a copy of the order or receipt for the goods;
 2. the serial or batch number printed on the machinery manufacturing plate; and
 3. a detailed description of the fault and how and when it arose; and
 4. If the fault is a type covered by this warranty, we will then make arrangements with you for the return of the goods to us (for repair or replacement) at our cost using our transport providers or we may decide to attend at your premises to repair or replace the goods.
- F. Our liability (and that of our resellers) under this warranty is wholly limited to repair or replacement of the goods (or those parts of the goods recognised as defective) in accordance with the procedure above and you have no right to other compensation, costs or damages under this warranty. But this does not mean that you may not have other rights under a law in relation to the goods.
- G. If following our inspection of goods returned by you under this warranty it is found that this warranty does not apply and you are not otherwise entitled to repair or replacement by us, you must, if requested by us, reimburse our costs including parts, labour and freight.
- H. This warranty is not transferable and only the person who purchased the goods may make a claim.

Where the goods have been exported outside Australia or New Zealand, the Company may not require the Purchaser to return any allegedly faulty or defective Product for evaluation. However, the Company has the right to request the return for evaluation at purchasers cost.

STATUTORY NOTICE

Our goods come with guarantees that cannot be excluded under the Australian Consumer Law. You are entitled to a replacement or refund for a major failure and for compensation for any other reasonably foreseeable loss or damage. You are also entitled to have the goods repaired or replaced if the goods fail to be of acceptable quality and the failure does not amount to a major failure.



Carbatec Pty Ltd

E info@carbatec.com.au

AU 1800 658 111

NZ 0800 444 329

128 Ingleston Road, Wakerley,
Queensland Australia 4154

ABN 84 010 706 242

carbatec®



CARBATEC.COM.AU